

The newsletter of the Sport Aircraft Association (Auckland Chapter) Inc

Sport Aviator

April 2019



Committee 2018/19

EXECUTIVE COMMITTEE

President: **Gary Briggs**
09 277 9959
021 168 7206

Vice President: **Scott Neill**
09 826 5655
027 479 3280

Secretary: **Keith Weale**
09 527 8710
027 435 4661

COMMITTEE MEMBERS

David Wilkinson **Gordon Lindsay**
021 468 270 09 534 2499
 021 265 4705

Bill Luther
021 790 276

OPERATIONAL POSITIONS

Treasurer **Newsletter Editor**
Gordon Sanders Gavin Magill
09 534 2464 07 866 0265
021 266 0585 027 291 0525

Safety Officer **Technical Library**
Norm Bartlett Rob Keith
09 528 0108 09 534 3845
027 611 2153

Tool Library **Airspace Users Group**
Manfred Scherbius Steve Chilcott
09 298 0221 09 376 3794
021 0813 6503 021 763 742

Catering **Webmaster**
Don Wilkinson Warren Sly
027 430 5303 021 772 351

TECHNICAL MENTORS

Wood & Fabric Mike Tunnicliffe 09 237 8173
Composites Alistair McLachlan 299 2775
Metal Skin Kevin Paulsen 296 5125
Avionics Liviu Filimon 268 1199

FRONT PAGE

David Wilkinson & Pat Sheehan congratulate each other following the successful first flight of Pat's RV-9A on Friday 5th April.

Contents

- 2 Committee 2018/19
- 3 Presidents Report
- 4 From the Editor
- 5 Chapter News
- 11 The Dead Horse Theory
- 12 Mystery Aircraft
- 13 In the News & On the Web
- 14 Upcoming Events
- 15 Sir Keith Park Bronze Unveiling

Next Meeting

WHEN: Thursday 25th April 2019

WHERE: Auckland Society of Model
Engineers Club Rooms
Peterson Road, Panmure Basin
Mt Wellington

SPEAKER: **Steve Groeneveld** is a retired Kiwi helicopter pilot and was with Alaska Airlines in the US. He will speak about his experiences tending oil rigs in the Gulf of Mexico.



Hi all

I hope you all had a great Easter. I have spent a week in Tauranga and had some of the best weather. I also visited the Classic Flyers Aviation museum which I thoroughly enjoyed - what a great little museum.

I popped into "Solo Wings" who are Rotax agents, for some oil and a filter for my Sonex as it's due for a fifty hour service.

Thank you all those who sent in submissions on the proposed ADS-B OUT mandate for controlled airspace, let's hope the CAA take into consideration our views on the matter.

A few members have gone down to Omaka for the Classic Fighters airshow, safe travels and I am sure they enjoyed it. I did not make it this year but have been a few years back and probably rates as one of the best airshows I have been to.

The Boeing 737 Max is due to test fly pretty soon as they have installed some new software which will sort out the problems with the trim system. Here is a link to the preliminary investigation report - [http://www.ecaa.gov.et/documents/20435/0/Preliminary+Report+B737-800MAX+,\(ET-AVJ\).pdf](http://www.ecaa.gov.et/documents/20435/0/Preliminary+Report+B737-800MAX+,(ET-AVJ).pdf) for those who are interested.

See you all on Thursday.



Hi Everyone.

Easter weekend has been and gone and it was mostly fine this year. The Sunday afternoon turned a bit pear

shaped for the Omaka Airshow but the event was otherwise enjoyable by all accounts. The Autumnal weather systems have definitely arrived but we have been fortunate that there has still been some good flying weather.

The big news for this edition of the newsletter is of course the first flight of Pat Sheehan's RV-9A on April 5th with David Wilkinson at the controls. Pat has provided some images from the day and an update for the newsletter and I would like to pass on my congratulations to Pat on this achievement following the 7.5 year build. ZK-VNS is a fine testament to Pat's skills and perseverance and I am looking forward to seeing Pat and his RV-9A at upcoming SAA Fly-Ins around the country.



Speaking of Fly-Ins, at the last SAANZ Council meeting it was agreed that the SAANZ SportAvex fly-in will be held over Waitangi Weekend in 2020 at Hawera aerodrome. Waitangi Day falls on Thursday February 6th next year so the fly-in will run from the 6th till the 9th. Pencil these dates in your diary and book a leave pass for the weekend. It is going to be a great event with camping on the field for those who wish to camp by their aircraft. It would be great to see a large turnout from the Auckland Chapter if possible to support this event.

Just a reminder of the unveiling of a statue to celebrate Air Chief Marshall Sir Keith Park at Thames on Saturday 27th April. Please see the flyer at the end of the newsletter for details. The unveiling is open to the public and I would encourage you to attend if possible.

Please note that I have taken the Friday off this week so I won't be in Auckland for this coming Thursday's meeting.

Enjoy the newsletter.

Cheers

Gavin

PROJECT NEWS

Pat Sheehan – Vans RV-9A ZK-VNS First Flight

By Pat Sheehan

My Van's RV-9A #92055 had its first flight on Friday 5 April 2019.



The challenge for me personally was to learn and undertake all the disciplines needed to complete this seven and half year build, eight if you include the paperwork!

The accumulated resources provided by all you guys in SAA is a valuable support and safety element. This makes the process a lot more enjoyable. That doesn't mean you don't get a little nervous on the day.



Can't thank Dave Wilkinson enough for his support and expertise – he may even come over from the dark side as he commented on how impressed he was with the nose wheels visibility.



ZK-VNS is fitted with a Lycoming O-320 with the Sensenich fixed pitch prop and is running on P-Mags. The avionics are by Dynon and Garmin, with power provided by dual alternators and an EarthX battery all managed by the VPX.



I need to stick around North Shore for the first 40 hours but then am looking forward to getting out and about.

A big thank you also to Chris Opperman for taking time out and providing these great images – can't do this on a cell phone!



PROJECT NEWS

Chris Wade / Pete Walton – RV-14

By Chris Wade

Some more progress photos from Chris Wade on Pete Walton's RV-14.



Chris says if it doesn't fly we can turn it into a boat



MEMBER NEWS

Evan Wheeler – New Toy

By Gavin Magill

Meant to include this last month. Evan has a new toy to go travelling about the countryside with the Missus. Evan tells me Michelle has been for a ride and likes it although he says the initial ride home from purchasing it was a bit hair-raising. Of course you can't have a sidecar without the authentic looking helmet. Plus Evan still has his old RNZAF full length woollen coat which looks the part as well. (Can't believe it still fits. I biffed all my uniform long ago.)



MEMBER NEWS

Gavin Magill – Fokker Smile

By Gavin Magill

I got to sit in Pete Walton's Fokker DR-1 last week and make aeroplane and machine gun noises. Pete says bugger the "RV Smile" check out the "Fokker Grin".



PROJECT NEWS

Pete Walton – Fokker DR-1

By Gavin Magill

Pete has been going flat out to get the Fokker to a taxi-able state and took it out for a spin over the Easter Weekend. Congrats Pete. Pete is now off to the US till October so no more updates on the Fokker till he returns.



MEMBER NEWS

Paul Carran – Vans RV-8

By Paul Carran

Paul on a recent trip to Raglan commented that "There must be a special on yellow paint. — at Raglan Airstrip."



PROJECT NEWS

Clint Kraidy – TEAM Airbike

By Gary Briggs

Clint Kraidy sent me this pic of his Airbike wing to put it in the newsletter.



PROJECT NEWS

Keith Weale – Vans RV-8

By Keith Weale

I have completed the installation of the instrument panel, all the avionics, and connected up the throttle and choke controls. I still need to do a final check before I pluck up the courage to switch the master on. I am quite a long way off from doing an engine start though. That will have to wait until I can find a hangar.



Avionics and engine installation completed



Instrument panel completed.

The image on the display is fake, courtesy of the Dynon brochure.

I have attached the tail cone, which has doubled the length of the aeroplane and halved the workshop space. I have become quite adept at limbo dancing as I move gracefully from one side of the aeroplane to the other – truly a sight to behold.

Just now I am back to where I started three and a half years ago completing and installing the empennage. I will have to build a cradle for the nose wheel so that I can jack it up high enough for her to become a tail dragger to fit the vertical stabiliser under the garage door.



An elaborate system of cushions and a dolly to substitute for that extra pair of hands were used when installing the stabilator. The garage door motor is switched off to avert disaster.

MEMBER NEWS

Barry Gillingwater - On The Move

By Barry Gillingwater

This will be my last mystery aeroplane. I will not be renewing my Auckland Chapter or my national SAAZ membership.

We have our house on the market and have decided to move down to Wanaka to be with our younger son and his family.

Thanks for everything.

Cheers Bazza

MEMBER NEWS

David Wilkinson – Omaka Trip

By David Wilkinson

Had a stunning day trip from Taupo to Omaka to catch up with John Corby. John is in great health and looking great.



Scott Montagu flew TNT down. I was airborne out of Taupo at 0620 and the sun came up as I was 4500 feet over National Park. It was a magic flight.



MEMBER NEWS

David Wilkinson – John Hansen Visit

By David Wilkinson

This is what you get when you land on your mate's farm strip (John Hansen) on the way to Taupo.



My daughter Emma and I enjoyed John and Christine's hospitality. We will arrange a BBQ lunch fly in at John's shortly. His strip is just west of Te Awamutu.

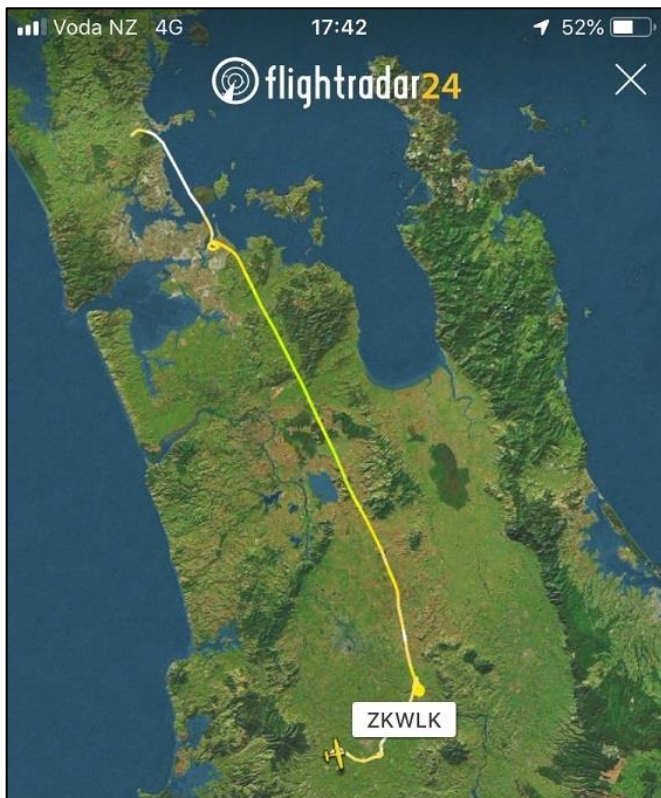

INDUSTRY NEWS

New Engine – Motorav

By Don Wilkinson

Expensive ? Maybe, maybe not?

Based on the Type 4 VW as in 911 Porsche but all redesigned with one piece C/S and prop flange.

Cost in NZ\$ around NZ\$22 or 24K. Not too bad compared to say Rotax 912 or UL.

Possibly will get up to 3.3L but they are sticking with 2.6L same as my late brother Ben's KR2 ZK-SLK, which was built with a 2.6L conversion and it went well.

For full details go to

<http://www.motorav.com/distributors.php>

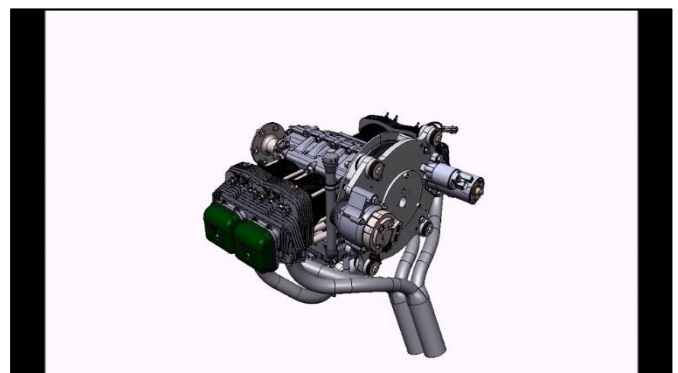
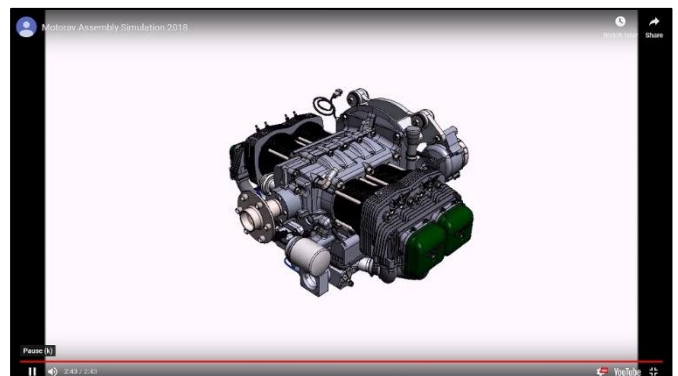

THE DEAD HORSE THEORY

The tribal wisdom of the Dakota Indians, passed on from generation to generation, says that,

"When you discover that you are riding a *dead horse*, the best strategy is to dismount."

However, in modern business, education and government, a whole range of far more advanced strategies often employed, such as.:

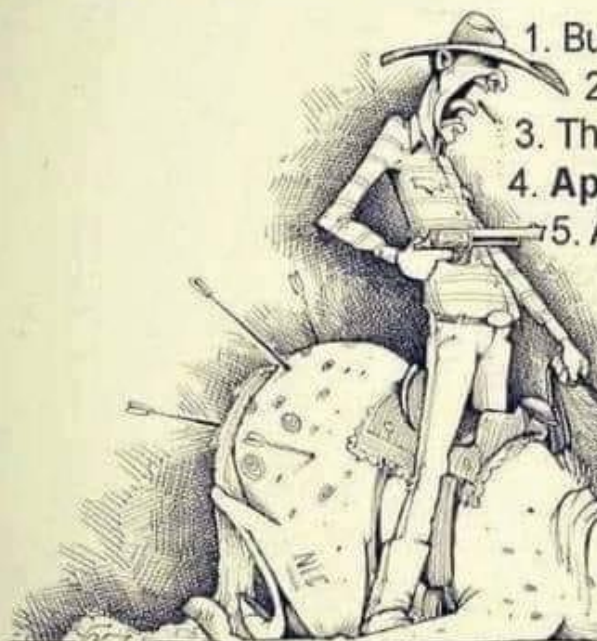
- 
1. Buying a **stronger whip**.
 2. **Changing** riders.
 3. Threatening the horse with **termination**
 4. **Appointing a committee** to study the horse.
 5. Arranging to **visit other countries** to see how others ride dead horses.
 6. **Lowering the standards** so that dead horses can be included.
 7. Re-classifying the dead horse as "**living impaired**".
 8. Hiring **outside contractors** to ride the dead horse.
 9. **Harnessing several** dead horses together to increase the speed.
 10. Providing **additional funding and/or training** to increase the dead horse's performance.
 11. Doing a **productivity study** to see if lighter riders would improve the dead horse's performance.
 12. Declaring that as the dead horse **does not have to be fed, it is less costly**, carries lower over head, and therefore contributes substantially more to the bottom line of the economy than do some other horses.
 13. **Re-writing the expected performance** requirements for all horses.
 14. **Promoting** the dead horse to a **supervisory position of hiring** another horse.

The mystery aircraft this month was provided by Barry Gillingwater. If you can identify it in time for the meeting this week you will earn yourself a chocky fish. This will be Barry's last mystery aircraft so give it a go.



ON THE WEB

Four Forces of Flight

Rob Keith

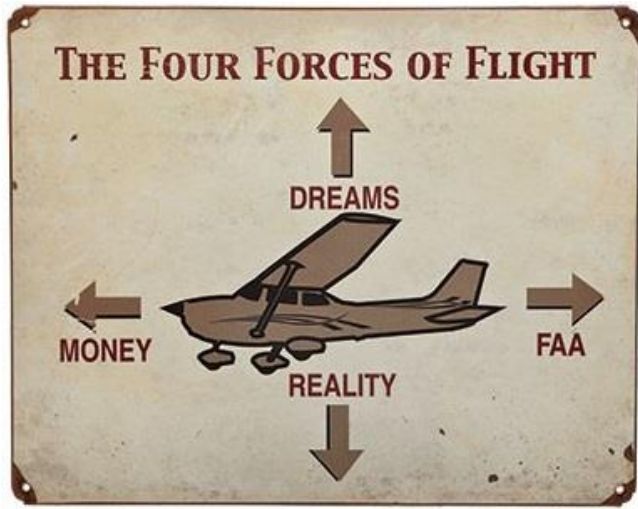

ON THE WEB

Indoor Models

Steve Stride

Gernot Bruckmann at IITOP 2014. International Indoor Tournament of Paris



<https://www.youtube.com/watch?v=Aex06p3hFYE>

ON THE WEB

Microlight Corsair

Keith Skilling

Cool Microlight Carbon Fibre Corsair on YouTube



https://youtu.be/B_juN-qFtU4

ON THE WEB

Pumpkin Dropping

David Wilkinson

This is hilarious.



https://www.youtube.com/watch?time_continue=9&v=orRjAZ8XasM

ON THE WEB

X31 – Breaking the Chain

Nev Hay

“If it can happen to the best team, it can happen to anyone. Know your chain links”



<https://youtu.be/x1E3xpePbmA>

ON THE WEB

Electric Amphibious Aircraft

Gavin Magill

Amphibious electric aircraft prototype achieves flight out of ground effect.



https://www.youtube.com/watch?v=AGDdC_2Tbt4&feature=youtu.be

Chapter Events

2019

Apr 25	Chapter Monthly Meeting Last Thursday of the month 7.30pm at the Auckland Society of Model Engineers clubrooms, Petersen Dr, Panmure Basin
---------------	--

Aviation Calendar 2019

2019

Every Sat	Dargaville Aero Club The place is buzzing every Sat, wet or fine, windy or calm, and the catered lunch at 12.30 is good value, just don't be late! Club website is http://dargavilleac.weebly.com/ . If going as a group, please ring in advance so the cook expects you. Ph. Murray 027-478 4308 or club house on 09-439 8024.
Apr 27	Sir Keith Park Bronze Unveiling Thames Civic Centre, Thames See flyer below for details.
Jul 22-28	EAA Airventure Oshkosh 2019 Wittman Field, Oshkosh Wisconsin, USA Celebrating 50 years of annual conventions at Oshkosh. The worlds greatest aviation celebration. www.eaa.org/en/airventure

Aviation Calendar 2020

2020

Feb 6-9	SAANZ SportAvex, Hawera. Annual summer fly-in (North Island's turn), a full program is planned, including competitions, AGM, annual dinner, Wings awards presentation. Details being progressively posted at www.saa.org.nz/public_pages/events.php
----------------	---

Air Chief Marshall Sir Keith Rodney Park

Arguably one of the world's greatest unsung heroes...

'If ever any one man won the Battle of Britain, he did. I don't believe it is realized how much that one man, with his leadership, his calm judgment and his skill, did to save not only this country, but the world'. Marshal of the RAF, Lord Tedder 1947



11AM
27 April 2019
Thames Civic Centre
Thames



A bronze of Sir Keith Park will be unveiled by the Honourable Ron Mark, New Zealand Minister of Defence and honoured by a Warbirds NZ Roaring Forties team flypast.

This will be followed by a presentation by Dr Adam Classen an expert in NZ aerial warfare and author of "Dogfight - The Battle of Britain" & "Fearless: The Extraordinary Untold Story of New Zealand's Great War Airmen".

A small FREE exhibition will run in the Civic Centre conference room, from late afternoon on 27th to 30th April, highlighting further details of Sir Keith's long and outstanding life, starting with his birth in Thames!

This will happen because one very private little old lady decided it should. As a proud New Zealander Yvonne Elizabeth Hare felt Sir Keith deserved greater recognition in his homeland. So, she left a bequest of NZ\$200,000 to create a bronze of Sir Keith to be installed in his home town of Thames. To do justice to Sir Keith and Miss Hare's bequest the executors of her estate are working with Thames-Coromandel District Council to make this an event we can all be proud of.

We hope you will join us to celebrate this great New Zealander and his achievements.

We ask that you wear your ANZAC poppies to this event to remember all those who have served.

Wendy Hare, Ralph Hare and Grant Robinson (Executors for the Estate of Miss Y E Hare)